

●Type K Plug

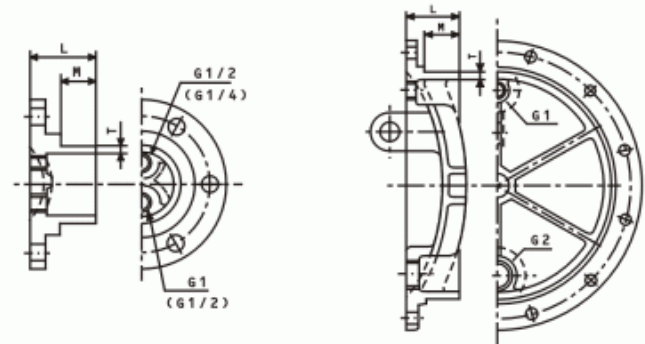

■ DN 75~250mm

■ DN 300 · 350mm

SHIN NAN CASTING FACTORY CO., LTD.

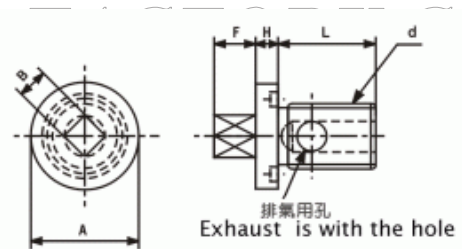

■排氣用螺栓 Bolt for exhausting (CNS 3270-403)

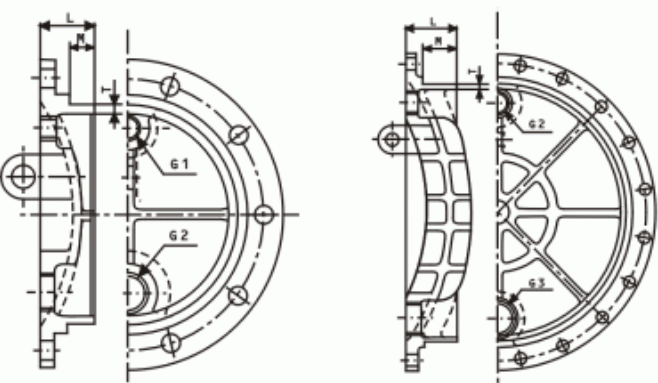

■ DN 400~500mm

■ DN 600~1500mm



■封環 Seal ring (CNS 10774-SBR IA · 70)

Unit: mm

Unit: mm

Nominal size	Thickness	Dimensions		Weight (kg)
		M	L	
75	8.5	55	92	5.29
100	8.5	55	93	7.26
150	9.0	55	94	11.00
200	11.0	55	95	16.20
250	12.0	55	96	22.20
300	12.5	85	127	33.20
350	13.0	85	128	43.30
400	14.0	85	129	56.40
450	14.5	85	130	67.00
500	15.0	85	131	79.70
600	16.0	85	132	121.00
700	17.0	95	143	172.00
800	18.0	95	144	257.00
900	19.0	95	145	340.00
1000	20.0	105	156	443.00
1100	21.0	105	158	547.00
1200	22.0	105	160	682.00
1350	24.0	105	162	922.00
1500	26.0	105	164	1200.00

Bolt for exhausting						Seal ring	
Thread Nom.	Dimensions					Dimensions	
	d	A	B	F	H	L	t
G 1/4	35	20	20	10	40	5.0	19
G 1/2	40	20	20	10	50	5.0	21
G 1	55	25	25	15	60	5.0	35
G 2	80	25	25	15	80	5.7	60
G 3	110	30	30	20	110	5.7	90

Note: 1. The water head drop (max.) of the plugs is 75m.

2. The dimensions in the brackets show the situation of DN 75~150mm.

3. The sign of the G means the CNS 494, and the plugs must have a bolt for exhausting.